

Criteria 3

Research, Innovations and Extension

Key Indicator 3.2

Innovation Ecosystem

3.2.1 Institution has created an ecosystem for innovations and has initiatives for creation and transfer of knowledge (patents filed, published, incubation center facilities in the HEI to be considered)

Rajarshi Shahu
College of Pharmacy

Journey Towards Academic Excellence

3.2.1 Institution has created an ecosystem for innovations and has initiatives for creation and transfer of knowledge (patents filed, published, incubation center facilities in the HEI to be considered)

Sr. No.	Contents	Page No. with Link
1	Information about Innovation Ecosystem	<u>1</u>
2	IIC – Certificate of Establishment	<u>2</u>
3	IIC Rating certificate 2018-19	<u>3</u>
4	IIC Rating certificate 2021-22	<u>4</u>
5	Appreciation Letter from Icon Enterprises & Company, Buldhana, Maharashtra for supporting innovation	<u>5</u>
6	Report and certificate of attendance at IIC Regional Meet, Nagpur	<u>6-11</u>
7	List and Reports of Activities organised under IIC	<u>12-31</u>
8	List and Proofs of Patents Published by RSCP, Buldhana	<u>32-63</u>

Innovation Ecosystem

The Institute focuses heavily on supporting innovation and creativity. We have established institution innovation council (IIC) as per the norms of Innovation cell, Ministry of HRD, Government of India during IIC calendar year 2018-19. Under IIC, the institute organized number of workshops and activities for students and staffs to explore and promote their innovative ideas.

The institute also promotes the faculties and students to work together and in collaboration to consolidate their ideas and bring out the prototypes and to file the patents for same. Institute also provides financial support to faculties and students under ARC policies for file a patent on innovative ideas which indirectly support start-up.

Institute is in the verge of establishing a dedicated incubation centre, but faculty members presently advise students on an individual basis to nourish their ideas for start-up. To foster mentor-mentee contacts for the development of an innovative ecosystem, we have included research activities as a key academic duty for local guardians. The planned incubation centre will make the best use of the available infrastructure and resources.

At present the available facilities are being utilized for extending training and instrumentation facilities. However, our team has envisaged an incubation centre with a vision "To establish effective a viable support system for scientific and entrepreneurial endeavours."

Our focus areas include:

- Nanotechnology based formulations
- Formulation of phytopharmaceuticals and nutraceuticals
- Preclinical evaluation of Drug or Herbals for different pharmacological activities
- *In silico* screening and custom synthesis of novel chemical entities
- Drug and food testing



Principal
Principal
Rajarshi Shahu College of Pharmacy,
Malvihir, Buldana.



CERTIFICATE

This is to certify that

RAJARSHI SHAHU COLLEGE OF PHARMACY, BULDANA

**has established Institution Innovation Council(IIC) as per the norms of Innovation Cell,
Ministry of HRD, Govt. of India during IIC Calendar year 2018-19**

Prof. Anil D. Sahasrabudhe
Chairman, AICTE

Certificate No : 990

Shri. R. Subrahmanyam
Secretary, MHRD

Dr. Abhay Jere
CIO, MHRD, Innovation Cell

Issuing Date: 17-12-2018



CERTIFICATE

Institution Innovation Council (IIC) established at

RAJARSHI SHAHU COLLEGE OF PHARMACY, BULDANA

had undertaken various activities prescribed by Innovation Cell, Ministry of HRD, Govt. of India to promote Innovation and Start-up in campus during the IIC calendar year 2018-19.

Prof. Anil D. Sahasrabudhe
Chairman, AICTE

Certificate No : 990

Shri. R. Subrahmanyam
Secretary, MHRD

Dr. Abhay Jere
CIO, MHRD, Innovation Cell

Issued On : 2019-11-06



Ministry of
Education
Government of India



MoE's
INNOVATION CELL
(GOVERNMENT OF INDIA)



INSTITUTION'S
INNOVATION
COUNCIL
(Ministry of Education Initiative)



CERTIFICATE

Institution's Innovation Council (IIC) established at

RAJARSHI SHAHU COLLEGE OF PHARMACY, BULDANA

had undertaken various activities prescribed by Innovation Cell, Ministry of Education, Govt. of India to promote Innovation and Start-up in campus during the IIC calendar year 2021-22.

Dr. Abhay Jere
Chief Innovation Officer
MOE, Innovation Cell

Mr. Dipan Sahu
Assistant Innovation Director
MOE, Innovation Cell

Certificate No : 990

Issued On : 2022-11-17



Reg.no. MH-07-A001313048

Contact info . 7020436110 mail id :- shadanakhan10@gmail.com

MR. SHADAN AHMAD

M. Pharm (Pharmacology)

Founder & M . D
(Icon Enterprises & Co.)



Ref. no. IR01

Date: 16/02/2021

To
Rajeshi shahu
College of pharmacy,
Buldana

Appreciation letter about Innovation and product development

It gives me immense pleasure to appreciate the innovation support provided by the Rajarshi Shahu College of Pharmacy, Buldhana during the year 2020-2021. We (Icon Enterprises Co) are small industry and have developed the products like Fabric Shampoo (August 2020), Floor Cleaners (November 2020). All this products are developed and guided by the faculties of RSCP, Buldhana on small to pilot scale during 2020-21. I really appreciate help & support provided by your organization to develop the above mentioned products and make them available in the market as finished products.

I appreciate your assistance very much and look forward to continuing our collaboration.

Thanking You

Seal

Shadan Ahmad

Name of the owner

Stamp

Icon Enterprises & Company

Buldana

Mob 8600056536

005

Reg . Head Office Address:-

Gawali pura ward no 5 Buldhana-443001, Maharashtra.



Rajarshi Shahu
College of Pharmacy

Journey Towards Academic Excellence

**Report and certificates of Attendance at
IIC Regional Meet, Nagpur**

Rajarshi Shahu College of Pharmacy, Botha Road, Malvahir, Buldhana 443001

Participated in

IIC Regional Meet at G. H. Raisoni College of Engineering, Nagpur

Date: 29/07/2022

Program Information

Title of activity	: IIC Regional Meet at G. H. Raisoni College of Engineering, Nagpur
Co-ordinator, Co-convenor	: Dr. Shailesh M. Kewatkar Dr. Vijay Borkar Prof. Satish Shelke Prof. Rushikesh Diware
Date	: 29/07/2022
Time	: 09.00 AM to 05.00 PM
Objective of program	: to aware various HEI's about IIC
Expected outcome	: HEI's like RSCP will come to know how IIC works and How it is useful for various stake holders
Funding agency (if any)	: NA
Total expenditure incurred	: NA
No. of participants	: 04

Geo Tagged Photos (if available), if it is online then add screenshots:



Rajarshi Shahu College of Pharmacy, Botha Road, Malvihir, Buldhana 443001

Participated in

IIC Regional Meet at G. H. Raisoni College of Engineering, Nagpur

Date: 29/07/2022

Program Summary

Rajarshi Shahu College of pharmacy, Buldana has participated in IIC regional meet at G. H. Raisoni College of Engineering, Nagpur on 29/07/2022. Our Start up and Innovative cell Coordinator **Dr. Shailesh M. Kewatkar** along with other IIC council members of RSCP i.e. **Dr. Vijay Borkar, Prof. Satish Shelke, Prof. Rushikesh Diware** were nominated for the event. Meeting was organized at G. H. Raisoni College of Engineering, Nagpur where various eminent personalities from AICTE, Delhi, DTE had addressed the meet related to IIC and its various portfolios. The first session was delivered by Dr. Dipan Sahu, AICTE, New Delhi in which he has shared the information related to various scheme under IIC. After this session there was a special arrangement for interactive session on IPR, NISP, ARIIA and IIC related information. Our council members has gathered all the information and interacted with the invited guest faculty members at event. We are thankful to hon'ble principal of RSCP, Buldana **Dr. Shirish P. Jain** Sir for giving the opportunity to be a part of this event. We will definitely follow the guidance provided by this meet and will try to inculcate all those activities at RSCP which will be beneficial for all the stake holders of RSCP.

Date: 30/07/2022



Principal
Principal
Rajarshi Shahu College of Pharmacy
Buldana.



Regional Meet
Institutions' Innovation Council
MoE's Innovation Cell

Certificate of Participation

Dr. Vijay Borkar

RAJARSHI SHAHU COLLEGE OF PHARMACY, Maharashtra

has participated in the regional meet held on 29th July 2022 at
G H Raisonni College of Engineering, Nagpur.

Dr. Dinesh Padole

President of IIC,
GHRCE, Nagpur

Mr. Dipan Sahu

Assistant Innovation Director
MoE's Innovation Cell



Regional Meet
Institutions' Innovation Council
MoE's Innovation Cell

Certificate of Participation

Rushikesh Gajanan Diware

RAJARSHI SHAHU COLLEGE OF PHARMACY, Maharashtra

has participated in the regional meet held on 29th July 2022 at
G H Raisonni College of Engineering, Nagpur.

Dr. Dinesh Padole

President of IIC,
GHRCE, Nagpur

Mr. Dipan Sahu

Assistant Innovation Director
MoE's Innovation Cell



Regional Meet
Institutions' Innovation Council
MoE's Innovation Cell

Certificate of Participation

DR. S. M. KEWATKAR

RAJARSHI SHAHU COLLEGE OF PHARMACY, Maharashtra

has participated in the regional meet held on 29th July 2022 at
G H Raisonni College of Engineering, Nagpur.

Dr. Dinesh Padole

President of IIC,
GHRCE, Nagpur

Mr. Dipan Sahu

Assistant Innovation Director
MoE's Innovation Cell



Regional Meet
Institutions' Innovation Council
MoE's Innovation Cell

Certificate of Participation

Satish Shelke

RAJARSHI SHAHU COLLEGE OF PHARMACY, Maharashtra

has participated in the regional meet held on 29th July 2022 at
G H Raisonni College of Engineering, Nagpur.

Dr. Dinesh Padole

President of IIC,
GHRCE, Nagpur

Mr. Dipan Sahu

Assistant Innovation Director
MoE's Innovation Cell



Rajarshi Shahu
College of Pharmacy

Journey Towards Academic Excellence

**List and Reports of Activities organised
under IIC**

List of Activities organised Under IIC

Sr. No.	Name of the workshop/ seminar/ conference	Date From – To	Page No. with Link
1	75 th Independence Day 2022: Celebration of Har Ghar Tiranga Activity	2022-08-13 to 2022-08-15	<u>13</u>
2	Online AICTE sponsored Short-Term-Training Program: Educational Program for Pharmacy Teachers on orientation of recently admitted students	2021-07-01 to 2022-02-28	<u>16</u>
3	Savitri Bai Phule Jayanti: Importance of nutrition diet in health	2022-01-04	<u>19</u>
4	National Energy Conservation day: Poster making competition on the occasion of Worlds Energy Conservation day	2021-12-14	<u>21</u>
5	Four Days Online Employability Skills Training Program	2021-11-15 to 2021-11-18	<u>23</u>
6	Plastic waste awareness drive: A void Single Used Plastic Waste	2021-10-24	<u>24</u>
7	One Day Workshop on Entrepreneurship Development Awareness	2021-09-30	<u>26</u>
8	World Pharmacist Day: Health Check-up and Free Medicine Distribution camp	2021-09-25	<u>27</u>
9	NSS Day 2021:Health worker's role in COVID-19: An Honor & Pride	2021-09-24	<u>30</u>

RajarshiShahu College of Pharmacy, Botha Road, Malvihir, Buldhana 443001
Organized
National Service Scheme Program

Program Information

Title of activity	: 75 th Independence Day 2022
Topic	: Celebration of Har Ghar Tiranga Activity
Coordinator/s	: Mr. Rohit Salkute
Convenor	: Dr. Shirish Jain, Principal
Date	: 13/08/2022 to 15/08/2022
Time	: 7:30am
Objective of program	: To celebrate 75 th Independence day of India under Har Ghar Tiranga activity
Expected outcome	: Fruitful contribution of team RSCP to make "Har Ghar Tiranga" activity successful.
Funding agency	: In house & SGBAU Amravati
No. of participants/delegates	: 450 students

RajarshiShahu College of Pharmacy, Botha Road, Malvihir, Buldhana 443001
Organized
National Service Scheme Program

Photos of event:

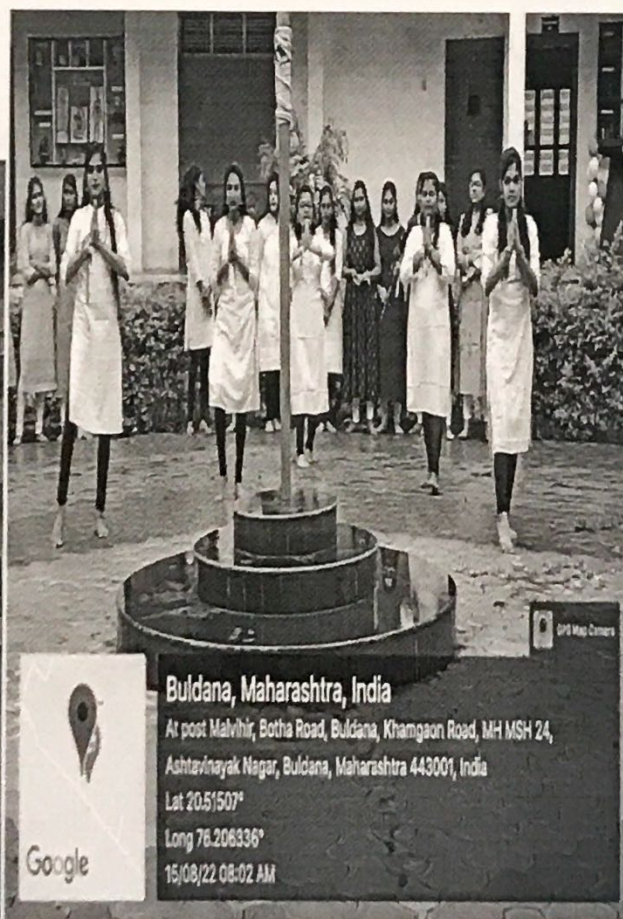
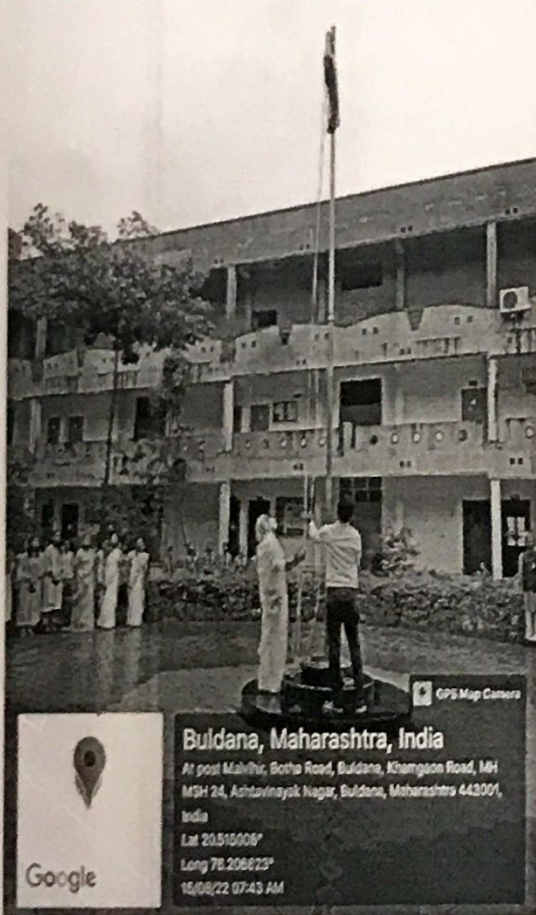

RajarshiShahu College of Pharmacy, Botha Road, Malvihir, Buldhana 443001

**Organized
National Service Scheme Program**

REPORT

75th Independence day Celebrated in RSCP Campus under the theme of Har Ghar Tiranga. Flag hosting was done by secretary of Dwarka Multipurpose foundations Mrs. Padmatai Sawale madm. During this activity schedule various types of completion such as Dance , Ranagoli, Group Songs were organised for students on theme of Har Ghar Tiranga. Students were performed dance on patriotic fusion song and added enthusiasms in the celebration.

Dr. Shirish jain(Principal, RSCP), Prof.Prakash Kendre, Prof. Shailesh Kewatkar, Prof. Gaurav Harlalka, Prof. Vijay Borkar, NSS program officer Prof. Rohit Salkute , Mrs. Shehal Deshmane, teaching staff , Non teaching staff and students were present to grace this occasion event a successful.

Date: 15/08/2022

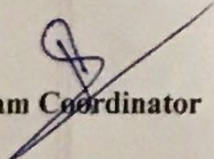
Program Coordinator

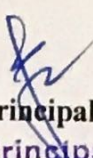

Principal
Principal
Rajarshi Shahu College of Pharmacy
Malvihir, Buldana.



DBUGVF's

Rajarshi Shahu College of Pharmacy, Buldana

(Approved by AICTE, PCI, New Delhi and affiliated to Sant Gadge Baba Amravati University, Amravati)

Program Information

Title of activity	: Online AICTE sponsored Short-Term-Training Program
Theme of the Program	: Educational Program for Pharmacy Teachers on orientation of recently admitted students
Program Coordinator	: Dr. Prakash Kendre (Institutional)
Date	: July 1, 2021 to July 6, 2021; July 27, 2021 to August 1, 2021; August 9, 2021 to August 14, 2021; February 23, 2022 to February 28, 2022
Time	: 10:30 AM to 1: 30 PM
Objective of the program	: Training of Pharmacy Teachers
Expected outcome	: Orientation of recently admitted students
Funding agency (If any)	: AICTE, New Delhi
Grant sanctioned	: 402000/-
Expenditure incurred	: 385000/-
Avg. No. of participants/delegates	: 450.
Screenshots of the program:	

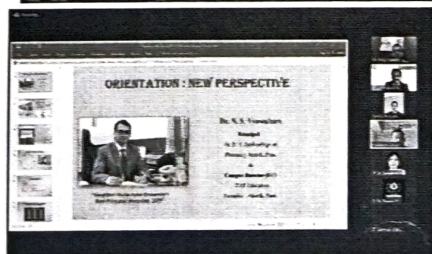
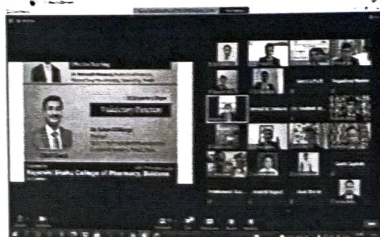
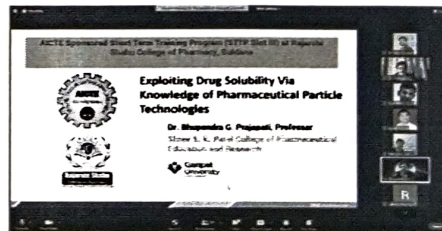
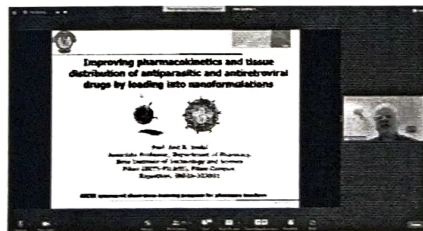
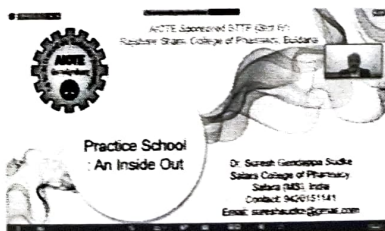
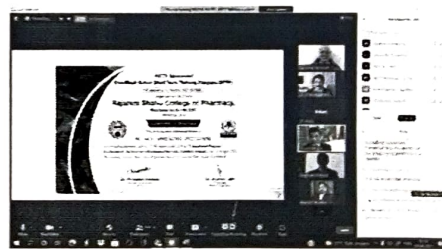
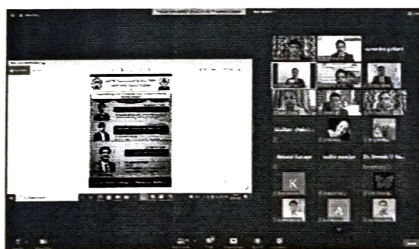

Program Summary Report

A short-term training program supported by the AICTE was successfully completed. The "Educational Program for Pharmacy Teachers on Orientation of Recently Admitted Students" was the theme of the program. The program was divided into four slots, each with two to three sessions per day, beginning on July 1, 2021. One of the eminent persons who inaugurated it was **Dr. Rajendra Kakde. He is an Advisor-I for the AICTE in New Delhi.** The event ended on July 6, 2021, with a keynote talk by Dr. Sohan Chitlange, Principal of the Dr. DYP Patil Institute of Pharmaceutical Sciences and Research, Pimpri, Pune.

Dr. Ranjit Barshikar, CEO of QbD International, officially opened the second slot on July 27, 2021. He spoke to the teachers about the significance of the induction program. Dr. Md. Salahuddin, Principal, Al-Ameen College of Pharmacy, Bangalore, was the Chief Guest during the completion of the second slot on August 1, 2021.

Dr. Pramod Katkade, Assistant Commissioner, FDA, Thane, Mumbai, officially opened the third slot on August 9, 2021. Dr. Krishnakant Gandhi, Managing Director, Solinova Life Sciences Pvt. Ltd. Hyderabad, was there when the third slot was completed on August 14, 2021.

On February 23, 2022, Dr. Col. B. Venkat, Director of the AICTE's Faculty Development Cell, New Delhi, officially opened the fourth slot. Dr. P. D. Chaudhari, Principal, Modern College of Pharmacy, Pune, was the Chief Guest at the completion of this slot on February 28, 2022.

Many notable speakers (totalling 70) from India and abroad, representing various reputable organizations, have delivered speeches on the program's theme during all of the AICTE-STTP slots. Teachers from all over India took part in this program, with an average of 450 participants showing up in each of the four slots.

We are grateful to the AICTE for providing us a grant of Rs. 402,000/- and allowing us to hold this event on an online platform due to the Corona-

Pandemic. We appreciate the unwavering support of all of the primary guests and prominent speakers, as well as all of the teacher-participants, in making this event a success.



Dr. Prakash Kendre

Program Coordinator



Dr. Shrish Jain

**Program Convener
Principal**

Rajarshi Shahu College of Pharmacy,
Malvihir, Buldana.

Program Information

Title of activity	: Savitri Bai Phule Jayanti
Topic	: Importance of nutrition diet in health
Coordinator/s	: Mr. Rohit Salkute
Convenor	: Dr. Shirish Jain
Date	: 04 January 2022
Time	: 04.00 PM To 05.30 PM
Objective of program	: To raise the importance of healthy nutritive diet To spread the awareness and importance of education for girl child's To cultivate the thoughts of Phule in girl students
Expected outcome	: Students were acquired knowledge & importance of nutrients in diet for healthy life Students were inspired by thoughts of Savitri Bai Phule in order to improve the education in girl child.
Funding agency	: Self-Funded (Institute Level)
No. of participants/delegates	: 87
Geo Tagged Photos (if available), if it is online then add screenshots:	



Rajarshi Shahu College of Pharmacy, Botha Road, Malvihir, Buldhana 443001
Organized
National Service Scheme Program

Savitri Bai Phule Jayanti Celebration Program Summary

Savitribai Phule Jayanti was celebrated at Rajarshi Shahu College of Pharmacy. On this occasion, under the guidance of Principal Dr. Shirish Jain, a dietician from Buldhana Dr. Sadhana Bhaote was invited as a chief guest. Dr. Sadhana Bhaote wasto guided female students to adopt a healthy nutrition die. Dr. Sadhana Bhaote provided guidance for the essential elements in the daily diet for the students and also solved the questions of the attendees.

On this occasion, the principal of the college, Dr. Shirish Jain, NSS advisor Dr. Vijay Borkar, Mr. Mangesh Deokar, NSS Program Officer Mr. Rohit Salkute, Miss. Nisha Gadia, Miss. Bhagyashree Budhwat was present. The program was hosted by Miss. Mrunal Mundhe and vote of thanks delivered by Miss. Prachi Chopade.

Date: 04 Jun 2022

Program Coordinator



Principal
Rajarshi Shahu College of Pharmacy
Malvihir, Buldhana.



Rajarshi Shahu College of Pharmacy, Botha Road, Malvihir, Buldhana 443001

Organized by
National Service Scheme Program

Program Information

Title of activity : National Energy Conservation day

Topic : Poster making competition on the occasion of Worlds Energy
Conservation day

Coordinator : Mr. Rohit Salkute

Convenor : Dr. Shirish Jain, Principal

Date : 14/12/2021

Time : 4PM

Objective of program: To aware students about motive to save energy resources

Expected outcome : The students should understand their responsibility regarding energy
conservation

No. of participants : 10

Photographic Evidence:

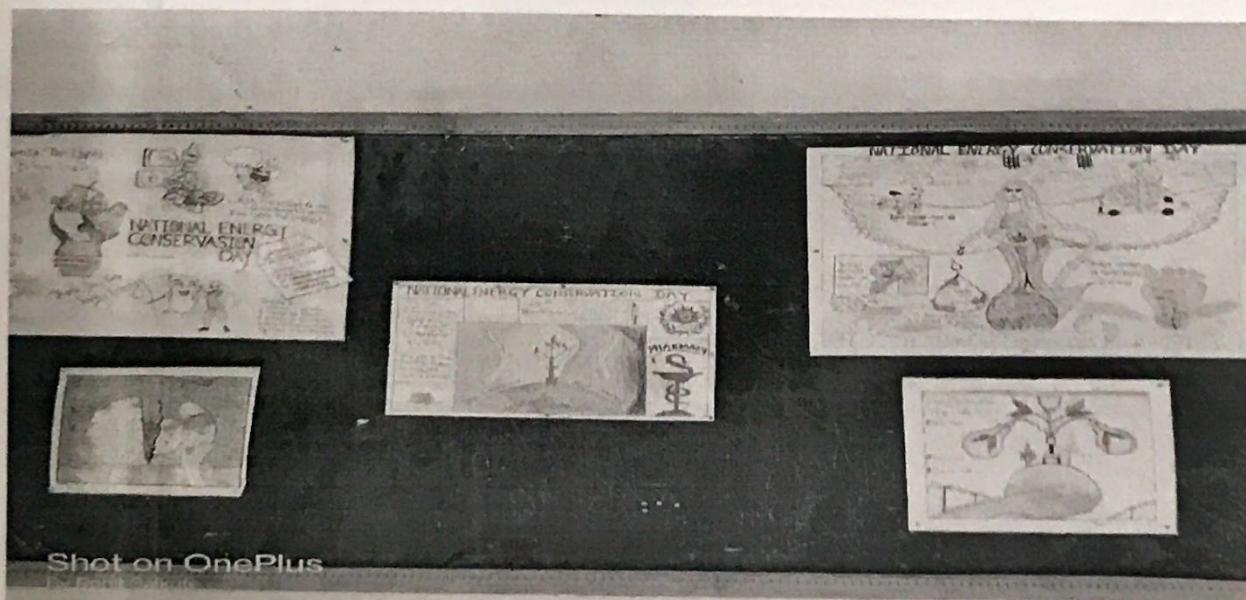

Rajarshi Shahu College of Pharmacy, Botha Road, Malvihir, Buldhana 443001

**Organized by
National Service Scheme Program**

Summary

NSS unit of Rajarshi Shahu College of Pharmacy organized Wall space Poster competition on the occasion of National energy conservation day. For this competition Prof. Somnath Vibhute and Prof. Subhash Deshmane were the judges of this competition.

Total 10 students from college prepare wall space poster on the theme of energy conservation. Out of this, Miss. Renuka Lajurkar and Group (B. Pharmacy 2nd year) was the First winner and Miss. Sakshi Sabale and group (B. Pharmacy 3rd year) was 2nd winner of this competition.

This program was arranged under the guidance of respected Dr. Shirish Jain sir and NSS advisory head Dr. Vijay Borkar by NSS Program Officer Mr. Rohit Salkute and all the enthusiastic volunteers of NSS UNIT. All team RSCP members were mentored these participants for preparing wall space posters. All NSS volunteers work hard to make this competition successful.

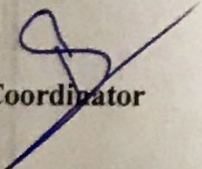
Program Coordinator



Principal
Rajarshi Shahu College of Pharmacy
Malvihir, Buldhana.



DBUGVF's

Rajarshi Shahu College of Pharmacy, Buldana
(Approved by AICTE, PCI, New Delhi and affiliated to Sant Gadge Baba Amravati University, Amravati)

Date: 18th Nov. 2021

Four Days Online Employability Skills Training Program

Training, Placement & Entrepreneurship Development Cell, Rajarshi Shahu College of Pharmacy, Buldana conducted Online Training program from 15th to 18th November 2021 on "Employability Skills" under "Life Skills" program organized by Rubicon, Pune

Objective: To enhance employability skills of students; this would help them significantly to increase their chance of succeeding in a job interview.

Topics covered: Organizational Structure, Public Speaking, Presentation Skills, E-mail Etiquette, Grooming, Group Discussion, Personal Interview.

Both the trainers Ms. Nidhi Madam and Ms. Pearl Madam were highly energetic and interacted with students in highly effective manner. Students expressed immense satisfaction and gratitude to institute for organizing this program.



Coordinator

Co-convenor

Convener/Principal
Principal
Rajarshi Shahu College of Pharmacy,
Malvihi, Buldana.

Program Information

Title of activity : Plastic waste awareness drive

Topic : "Avoid Single Used Plastic Waste".

Coordinator/s : Mr. Rohit Salkute

Convenor : Dr. Shirish Jain

Date : 24 October 2021

Time : 10.30 AM To 05.30 PM

Objective of program : To make awareness in students about reduction in usage of plastic along with problem and impact of plastic pollution on human health

Expected outcome : From this program students were learned and awared about plastic usage, pollution and its impact on environment as well as on human health

Funding agency : Self-Funded (Institute Level)

No. of participants/delegates : 142

Geo Tagged Photos (if available), if it is online then add screenshots:



Rajarshi Shahu College of Pharmacy, Botha Road, Malvihir, Buldhana 443001
Organized
National Service Scheme Program

Plastic waste awareness drive Program Summary

Rajarshi Shahu College of Pharmacy Buldhana NSS Unit had organized road shows at various places in Buldhana on the theme "Avoid Single Used Plastic Waste".

The event was organized by NSS at Sunderkhed Stop, Karanja Chowk, Bus Stand premises in Buldhana to create awareness and clean the premises. At this time, under the guidance of the principal of the college, Dr. S. P. Jain, Dr. Vijay Borkar, Shri. Parmeshwar Devhare, NSS Program Officer Shri. Rohit Salkute and volunteers were present. In this street play, volunteer Rohit Pawar dressed up as Sant Gadge Baba and shed light on the burning issue that there is a real need to avoid disposable plastic waste.

Date: 24 Oct 2021

Program Coordinator



Principal
Rajarshi Shahu College of Pharmacy
Malvihir, Buldana.





DBUGVF's
Rajarshi Shahu College of Pharmacy, Buldana
(Approved by AICTE, PCI, New Delhi and affiliated to Sant Gadge Baba Amravati University, Amravati)

One Day Workshop on 'Entrepreneurship Development Awareness'

Training, Placement and Entrepreneurship Development Cell of our college Organized One Day Workshop on 'Entrepreneurship Development Awareness' on Date: 30th Sept.2021 Time: 11: 00 AM-3:30 PM. The main objective of this workshop was to create awareness of entrepreneurship among students and to explore opportunities. Mr. Pradip Chavan- Founder Prachoday Consultant, Nagpur inaugurated the event and delivered the key note address. Mr. Ganesh Gupta Project Officer, MCED, Buldana explained the role of MCED in entrepreneurship development. Mr. Netradeep Chaudhary-Founder & CEO SN Associates guided students on banking support for entrepreneurship development. Mr. Rajiv Jawale-Founder & Managing Director Abhaalmaya Agro Products Ltd., shared important tips on how to explore market for business? Dr. Shirang Chaphekar-Director Shree Brahmachaitanya Ayurved graced the event as the chief guest of valedictory function.

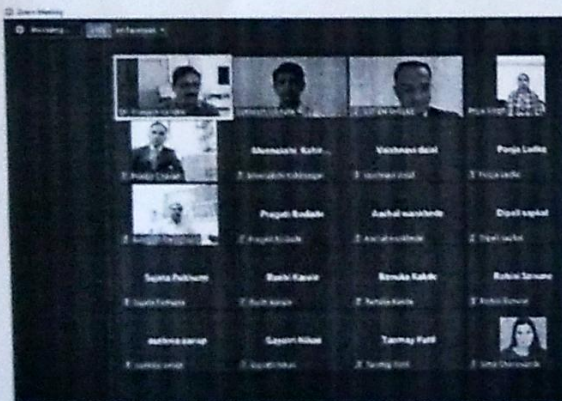
Total 389 participants from various parts of Maharashtra participated in this workshop.

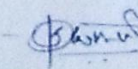

Coordinator

Co-convener

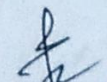
Principal
Rajarshi Shahu College of Pharmacy,
Malvihi, Buldana.



Rajarshi Shahu College of Pharmacy, Botha Road, Malvihir, Buldhana 443001

Organized by
National Service Scheme Program

Program Information

Title of activity : WORLD PHARMACIST DAY

Topic : Health Check up and Free Medicine Distribution camp for NSS
Unit adopted village Sakhali BK.

Coordinator : Mr. Rohit Salkute

Convenor : Dr. Shirish Jain, Principal

Date : 25/09/2021

Time : 10AM -3 PM

Objective of program: To aware students about motive to highlight role of Pharmacist in the Society & regarding safety use of medication

Expected outcome : The students should understand their responsibility being as pharmacist

Funding agency : In House and SGBAU

No. of participants : 50

Rajarshi Shahu College of Pharmacy, Botha Road, Malvihir, Buldhana 443001
Organized by
National Service Scheme Program

Photographic Evidence:



Rajarshi Shahu College of Pharmacy, Botha Road, Malvihir, Buldhana 443001
Organized by
National Service Scheme Program

Summary

Pharmacy: Always trusted for your health”RAJARSHI SHAHU COLLEGE OF PHARMACY BULDHANA’s NSS Unit Organised Health Check up camp and free Medicines distribution on the occasion of World Pharmacist Day for the Needy people’s of NSS Adopted Village Sakhali Bk. and native village Malvihir. This “Maha-aarogya Shibir” by was started by Lamp Lighting by Chief guest of program respected Dr. Vikasji Bahekar(Eye Specialist) and President of Program respected principal Dr. Shirish Jain sir and other well know doctors team from Buldhana district.

For Eye related patients Dr. Vikashji Bahekar, Dr. Priti Baherkar , Dr. Madhuri Patil Madam, Dr. Ravi Shinde sir are serve the humanity for this noble cause.For Dental related issues Dr. Dhanajay Bhusari, Dr. Pooja Warade, Dr. Mundhe Madam, other dentist from Civil hospital Buldhana were helped the Needy people’s identified from NSS UNIT in survey done before few days. For other Disease Dr. Bhagwat Bhusari ,Dr. Shantanu Deshmukh ,Dr. Ananta Magar, Dr. Rushikesh Magar ,Dr. Vishal Lahane Dr. Nirkhe and other team members were contributed in serving humanity. Near about 300 patients from both village were taken advantage of this Health Check up camp and all volunteers of NSS peacefully. There was blood donation camp also arranged by NSS VOLUNTEERS with help of Dr. Shital Pawar madam from civil hospital.

Many staff members and Volunteers also donated blood taking consideration of unavailability in blood bank on this occasion of Pharmacist Day.

This program was arranged under the guidance of respected Dr. Shirish Jain sir and NSS advisory head Dr. Vijay Borkar by NSS Program Officer Mr. Rohit Salkute and all the enthusiastic volunteers of NSS UNIT .All team RSCP members were mentored these volunteers during this program. Every volunteer were had feeling of something done great for society at the end of day.

Program Coordinator



Principal
Rajarshi Shahu College of Pharmacy,
Malvihir, Buldana.
Principal

Rajarshi Shahu College of Pharmacy, Botha Road, Malvihir, Buldhana 443001
Organized
National Service Scheme Program

Program Information

Title of activity	: NSS Day 2021
Topic	: Health worker's role in COVID-19 : An Honor & Pride
Coordinator/s	: Mr. Rohit Salkute
Convenor	: Dr. Shirish Jain
Date	: 24 September 2021
Time	: 10.30 AM To 05.30 PM
Objective of program	: To raise the inspiration, motivation, respect and importance among students about frontline health workers
Expected outcome	: From this program students were learned about dedication, efforts and importance of health workers in COVID-19 condition.
Funding agency	: Self-Funded (Institute Level)
No. of participants/delegates	: 138
Geo Tagged Photos (if available), if it is online then add screenshots:	



Rajarshi Shahu College of Pharmacy, Botha Road, Malvihir, Buldhana 443001
Organized
National Service Scheme Program

Celebration of NSS Day 2021 Program Summary

The devastating second wave of Covid-19 made people realize the importance of healthcare workers like never before. Doctors, nurses, healthcare workers, assistants and sanitary workers at hospitals were honoured as Covid warriors. But pharmacists, one of the main pillars of the healthcare system and unsung heroes of the pandemic, still feel neglected.

We as a part of this community, feels that we should express our gratitude Towards the Pharmacist on the occasion of NSS Day 2021. Our volunteers distributed expression of gratitude to the All Pharmacist as unsung heroes. Also campus cleaning was done on this day for tommarows Heath Checkup camp event.

This activity was conducted under the guidance of respected Principal Dr. Shirish Jain sir, Dr Prakash Kendre sir and Mr. Sharad Tayade sir by Mr. Rohit Salkute (NSS program officer) and all the volunteers of NSS.

Date: 24 Sept 2021

Program Coordinator



Principal
Rajarshi Shahu College of Pharmacy,
Malvihir, Buldhana.
Principal



Rajarshi Shahu
College of Pharmacy

Journey Towards Academic Excellence

List and Proofs of Patents Published by
RSCP, Buldhana

List of Patent Published

(2016-2022)

Sr. No.	Patent Application No.	Status of Patent (Published / Granted)	Published Year	Inventor/s Name	Title of the Patent	Page No. with Link
1	202021056513	Published	2022	Chakolkar Madhav Devendra, Tayade Sharad Dinkarrao, Tapadiya Shweta Ganesh, Waghmare Aditi Ganesh, Chavan Mayuri Ghanshyam	A Digital Medicine Storing Box	<u>37</u>
2	202141058058	Published	2022	Tarun Kumar, Dr. Sachin Tyagi, Dr. Manoj Shrawan Charde, Dr. Rita Dadarao Chakole, Madhav Chakolkar , Dr. Rajeev Ranjan	Effective Drugs Analysis for Covid-19 Pandemic Using Randomized Multivariable Machine Learning Approach	<u>38</u>
3	20 2022 100 063	Granted (Germany)	2022	Chakolkar Madhav, Jain Shirish Premchand, Karunakaran Rohini, Kumar Satendra, Ojha Garima, Sharma Divya, Sharma Jyoti, Srikumar Padmalayam, Sadanandan, Vig Himangi, Wal Pranay	Sustained Released Liposomal Cytotoxic Drug Formulation	<u>39</u>
4	202211003749	Published	2022	Dr. Manmeet Singh Saluja, Dr. Shailesh M Kewatkar , Ms Vidhi Jain, Dr. Ajay Sharma, Dr Chandra Shekhar Sharma, Dr.Deshbandhu Joshi	Extraction And Anticancer Activity Of Medicinal Plant	<u>40</u>

Sr. No.	Patent Application No.	Status of Patent (Published / Granted)	Published Year	Inventor/s Name	Title of the Patent	Page No.
5	20 2022 100 985	Granted (Germany)	2022	Chakolkar Madhav Devendra , Khandai Madhusmruti, Kumar Verma Navneet, Singh Amrita, Tyagi Sachin, Upadhyay Swarnakshi, Verma Garima, Wadhwa Simran, Wal Pranay,	Portable vaccine storage device	<u>42</u>
6	202221006708	Published	2022	Prof. Utkarsh P. Nigam, Dr. Sanjaykumar Kanubhai Dave, Dr. Krunal H. Patel, Adil A. Haji, Madhav Chakolkar , Anumita Bhadra	Methodology And Composition Of Mix Proportion Of Self Compacting Precast Floor Tile Utilising Sugarcane Ash	<u>43</u>
7	2021105078	Granted (Australia)	2022	Vishal Pande, Mahendra Giri , Rasika Bhalke, Shamila Kuskar, Pallavi Chede, Vikas Ahirrao, Ajinkya Pote , Sudhir Parbhane, Aishwarya Shinde	A Novel Formulation of Chitosan Nanoparticles	<u>44</u>
8	202211017496	Published	2022	Dr. Manmeet Singh Saluja, Dr. Shailesh M Kewatkar , Dr. Ajay Sharma, Dr. Kinjal Hareshkumar Shah, Dr. Ashim Kumar Sen, Mr. Ajay Kumar, Ms. Shilpi Mishra	Extraction And Anticancer Activity Of Madhuca Longifolia	<u>45</u>
9	Design No. 353855-001	Design Patent (Granted - Indian)	2022	Dr. Manish Joshi, Madhav Chakolkar , Rahul Kanaoujiya, Dr. Kalpana Sengar,	Testing Device For Checking Purity and Nutritional Content of Milk Product	<u>47</u>

Sr. No.	Patent Application No.	Status of Patent (Published / Granted)	Published Year	Inventor/s Name	Title of the Patent	Page No.
10	201821009015	Granted (Indian)	2022	Dr. Moharmutd Aijaz Ayyub Sheikh, Navale Sainath Ramnath, Dr. Shirish Jain, Madhav Chakolkar	A Process For Preparation Of Pellets Of Theophylline Drug	<u>48</u>
11	202221041441	Published	2022	Madhav Devendra Chakolkar, Dr. Shirish Premachand Jain , Vaibhav Uddhav Chinchole, Shubham Subhash Sarode	A Diagnostic Test By Using Saponins For Detection Of Occult Blood In Urine And Stool Sample	<u>49</u>
12	202121042106	Published	2022	Madhav Devendra Chakolkar, Akshay Sanjay Mahalle, Indira Puroshattam Dahibhat, Shirish Premachand Jain, Dr. Puroshottam Gangane, Sachin Rajendra Jadhav, Dr. Swati S. Tathod	FORMULATION FOR THE TREATMENT OF PARONYCHIA AND METHOD OF PREPARATION THEREOF	<u>50</u>
13	Design No. - 364452-001	(Design Patent) Published	2022	Madhav Chakolkar, Satish Panjabrao Shelke, Purushottam Gangane, Dr. Sohan Chitlange	Device for Blood Sample Analysis	<u>51</u>
14	Design No.- 356181-001	(Design Patent) Published	2022	Neelam Sanjeev Kumar, Mohd Yunus Khan, Dr. Nandkishor Dinkarrao Gawhale, Madhav Chakolkar	Oxygen Generator	<u>53</u>
15	202022104209	Granted (Germany)	2022	Bhise Manish Ramesh, Chandurkar Pranjali Wamanrao, Goda Chirag Chandrakant, Kandalkar Ashish Madhukar, Pahuja Sunny Ramchand, Patil Vikas Prakash, Patond Vishal	Modern drug formulation for cancer therapy	<u>55</u>

Sr. No.	Patent Application No.	Status of Patent (Published / Granted)	Published Year	Inventor/s Name	Title of the Patent	Page No.
				Babulal, Shejol Vinayak Mahadeo, Shelke Satish Panjabrao , Shukla Karunakar, Vasu Sanjay Namdevrao		
16	202022105415	Granted (Germany)	2022	Chakolkar Madhav Devondra , Gangano Purushottam Shirdharrao, Gawhale Nandklshor, Joshi Amit, Kewalkar Shallesh , Kulkaml Abhijeet Dattotraya, Saluja Manmeet Singh, Sawarkar Harlgopal Shalimar, Shaikh Mohammad Alju Ayyub	A storage box for digital medicines	56
17	202121054080	Published	2021	Dr. Gopal Ramchandra Kulkarni, Dr. Akhilesh Kumar, Fardin Ahmed Niloy, Fazeel Abid, Rohit Salkute , N. Priya	A Novel Method for Prevention of Security Attack on Cloud Medical Data Using Artificial Intelligence and Iot	57
18	202111057428	Published	2021	Dr. Sheela Devi, Dr. Smita Sharma, Dr. Sheshang Degadwala, Dipak Bhusari , Balaji Ramkumar Rajagopal, Nabamita Deb	Deep Learning Enabled Cloud Based Iot And Machine Learning Implemented System For Detecting And Preventing Heart Abnormalities	58
19	202111058061	Published	2021	Rahul Kanaoujiya, Madhav Chakolkar , Dr. Hemant Gangrude, Dr. Manisha M. Kodape, Ajaykumar Ramhari Motghare, Dr. Shubhajit Halder	Synthesis of N-Mannich Bases of 3,4 Dihydropyrimidin-2(1H)-ones by using Fe ₃ O ₄ @SiO ₂ @Et-PhSO ₃ H as magnetically retrievable nanocatalysts	59



DBUGVF's

Rajarshi Shahu College of Pharmacy, Buldana

(Approved by AICTE, PCI, New Delhi and affiliated to SantGadge Baba Amravati University, Amravati)

Sr. No.	Patent Application No.	Status of Patent (Published / Granted)	Published Year	Inventor/s Name	Title of the Patent	Page No.
20	202121049931	Published	2021	Dr. Shailesh M. Kewatkar, Mr. Madhav D. Chakolkar, Dr. Shirish P. Jain, Mr. Dipak V Bhusari	Herbal Hair Oil For Hair Fall Treatment	<u>60</u>
21	201921024417	Published	2020	Mr. Madhav Chakolkar, Dr. Shirish Premchand Jain, Dr. Shailesh Madhukar Kewatkar, Mr. Anand Bhanudas Kafre, Ankush Arun Sapkal, Vrushali Eknath kalwaghe	Apparatus for the extraction of a lipid from solid material	<u>61</u>
22	201921039880	Published	2020	Dr. Shirish P. Jain, Mr. Amit Kumar K. Tawri, Mr. Ankush P. Kharche, Dr. Shailesh M. Kewatkar, Mr. Gyaneshwar G Farkale, Mr. Madhav D. Chakolkar	Novel Soxhlet Apparatus	<u>62</u>
23	201921039358	Published	2020	Prakash Namdeo Kendre, Somnath Kedarling Vibhute, Shirish Premchand Jain	Composition And Process For Preparation Of Curcumin Film Forming Spray For Wound Healing	<u>63</u>



Office of the Controller General of Patents, Designs & Trade Marks
Department of Industrial Policy & Promotion,
Ministry of Commerce & Industry,
Government of India

(<http://ipindia.nic.in/index.htm>)



(<http://ipindia.nic.in/index.htm>)

Application Details

APPLICATION NUMBER	202021056513
APPLICATION TYPE	ORDINARY APPLICATION
DATE OF FILING	26/12/2020
APPLICANT NAME	1 . CHAKOLKAR MADHAV DEVENDRA 2 . TAYADE SHARAD DINKARRAO 3 . TAPADIYA SHWETA GANESH 4 . WAGHMARE ADITI GANESH 5 . CHAVAN MAYURI GHANSHYAM
TITLE OF INVENTION	A DIGITAL MEDICINE STORING BOX
FIELD OF INVENTION	BIO-MEDICAL ENGINEERING
E-MAIL (As Per Record)	infobli100@gmail.com
ADDITIONAL-EMAIL (As Per Record)	sjgawande@gmail.com
E-MAIL (UPDATED Online)	ashutosh@bliconsultancy.co.in
PRIORITY DATE	
REQUEST FOR EXAMINATION DATE	--
PUBLICATION DATE (U/S 11A)	21/01/2022

Application Status

APPLICATION STATUS	Awaiting Request for Examination
--------------------	---

[View Documents](#)

037



Office of the Controller General of Patents, Designs & Trade Marks
Department of Industrial Policy & Promotion,
Ministry of Commerce & Industry,
Government of India

(<http://ipindia.nic.in/index.htm>)



(<http://ipindia.nic.in/index.htm>)

Application Details	
APPLICATION NUMBER	202141058058
APPLICATION TYPE	ORDINARY APPLICATION
DATE OF FILING	13/12/2021
APPLICANT NAME	1 . Tarun Kumar 2 . Dr. Sachin Tyagi 3 . Dr. Manoj Shrawan Charde 4 . Dr. Rita Dadarao Chakole 5 . Madhav Chakolkar 6 . Dr. Rajeev Ranjan
TITLE OF INVENTION	EFFECTIVE DRUGS ANALYSIS FOR COVID-19 PANDEMIC USING RANDOMIZED MULTIVARIABLE MACHINE LEARNING APPROACH
FIELD OF INVENTION	COMPUTER SCIENCE
E-MAIL (As Per Record)	soni.mukesh15@gmail.com
ADDITIONAL-EMAIL (As Per Record)	
E-MAIL (UPDATED Online)	
PRIORITY DATE	
REQUEST FOR EXAMINATION DATE	--
PUBLICATION DATE (U/S 11A)	28/01/2022

Application Status	
APPLICATION STATUS	Awaiting Request for Examination

			View Documents 038
--	--	--	---

Urkunde

über die Eintragung des
Gebrauchsmusters Nr. 20 2022 100 063

Bezeichnung:

Liposomale zytotoxische Arzneimittelformulierung mit verzögerter Freisetzung

IPC:

A61K 9/127

Inhaber/Inhaberin:

Chakolkar, Madhav, Karanjlad, IN
Jain, Shirish Premchand, Dr., Buldhana, IN
Karunakaran, Rohini, Dr., Bedong, MY
Kumar, Satendra, Dr., Deoria, IN
Ojha, Garima, Dr., Kanpur, IN
Sharma, Divya, Patiala, IN
Sharma, Jyoti, Patiala, IN
Srikumar, Padmalayam Sadanandan, Dr., Bedong, MY
Vig, Himangi, Gorakhpur, IN
Wal, Pranay, Dr., Kanpur, IN

Tag der Anmeldung:

04.01.2022

Tag der Eintragung:

04.02.2022

Die Präsidentin des Deutschen Patent- und Markenamts



Cornelia Rudloff-Schäffer

München, 04.02.2022



पेटेंट कार्यालय
शासकीय जर्नल

**OFFICIAL JOURNAL
OF
THE PATENT OFFICE**

निर्गमन सं. 05/2022
ISSUE NO. 05/2022

शुक्रवार
FRIDAY

दिनांक: 04/02/2022
DATE: 04/02/2022

पेटेंट कार्यालय का एक प्रकाशन
PUBLICATION OF THE PATENT OFFICE

(12) PATENT APPLICATION PUBLICATION

(21) Application No.202211003749 A

(19) INDIA

(22) Date of filing of Application :23/01/2022

(43) Publication Date : 04/02/2022

(54) Title of the invention : EXTRACTION AND ANTICANCER ACTIVITY OF MEDICINAL PLANT

(51) International classification :G06F0009455000, B32B0037120000, B01D0011020000, H01L0021683000, G16B0030000000
(86) International Application No :NA
Filing Date :NA
(87) International Publication No : NA
(61) Patent of Addition to Application Number :NA
Filing Date :NA
(62) Divisional to Application Number :NA
Filing Date :NA

(71)Name of Applicant :

1)Dr. Manmeet Singh Saluja

Address of Applicant :Principal Gurukul Pharmacy College
Kota Rajasthan Email id: mansivcp@gmail.com Mob
No.77708488888 -----

2)Dr. Shailesh M Kewatkar.

3)Ms Vidhi jain

4)Dr. Ajay Sharma

5)Dr Chandra Shekhar Sharma

6)Dr.Deshbandhu Joshi

Name of Applicant : NA

Address of Applicant : NA

(72)Name of Inventor :

1)Dr. Manmeet Singh Saluja

Address of Applicant :Principal Gurukul Pharmacy College Kota
Rajasthan Email id: mansivcp@gmail.com Mob No.77708488888

2)Dr. Shailesh M Kewatkar.

Address of Applicant :Associate Professor & head, Department of
Pharmacognosy Rajarshi Shahu College of Pharmacy, Buldana,
Maharashtra. Email id: kewatar.shailesh@gmail.com Mob.no.
09589941146 -----

3)Ms Vidhi jain

Address of Applicant :Associate Professor Kota College Of
Pharmacy Kota, Rajasthan Email id: jain.vidhi911@gmail.com
Mobile No. 8005926603 -----

4)Dr. Ajay Sharma

Address of Applicant :Prof and Vice Principal, MIPS Mahakal
Institute of Pharmaceutical Studie, Ujjain, MP Email
id:ajaysharma85@gmail.com Mobile No. 9827687111 -----

5)Dr Chandra Shekhar Sharma

Address of Applicant :Associate Professor, B N college Of
Pharmacy Udaipur, Rajasthan Email id: cssmedchem@gmail.com
Mobile No. 9828173650 -----

6)Dr.Deshbandhu Joshi

Address of Applicant :Professor, Shrinathji Institute Of Pharmacy
Nathdwara, Rajasthan Email id: rinkesh5768@gmail.com Mobile
No. 8005937014 -----

(57) Abstract :

The main object of present invention is to evaluate the anticancer activity of Madhucalongifolia, Adinacordifolia, Sidaveronicaefolia. Further invention related to process for preparation of extraction and isolation of medicinal plant by using different solvent

No. of Pages : 30 No. of Claims : 3

Urkunde

über die Eintragung des
Gebrauchsmusters Nr. 20 2022 100 985

Bezeichnung:

Tragbare Impfstoffaufbewahrungsvorrichtung

IPC:

F25B 21/02

Inhaber/Inhaberin:

Chakolkar, Madhav Devendra, Buldhana, IN
Khandai, Madhusmriti, Dr., Berhampur, IN
Kumar Verma, Navneet, Gorakhpur, IN
Singh, Amrita, Kanpur, IN
Tyagi, Sachin, Dr., Meerut, IN
Upadhyay, Swamakshi, Kanpur, IN
Verma, Garima, Greater Noida, IN
Wadhwa, Simran, Kanpur, IN
Wal, Pranay, Dr., Kanpur, IN

Tag der Anmeldung:

22.02.2022

Tag der Eintragung:

01.03.2022

Die Präsidentin des Deutschen Patent- und Markenamts



Cornelia Rudloff-Schäffer

München, 01.03.2022





Office of the Controller General of Patents, Designs & Trade Marks
Department of Industrial Policy & Promotion,
Ministry of Commerce & Industry,
Government of India

(<http://ipindia.nic.in/index.htm>)



(<http://ipindia.nic.in/index.htm>)

Application Details

APPLICATION NUMBER	202221006708
APPLICATION TYPE	ORDINARY APPLICATION
DATE OF FILING	08/02/2022
APPLICANT NAME	1 . Prof. Utkarsh P. Nigam 2 . Dr. SANJAYKUMAR KANUBHAI DAVE 3 . Dr. Krunal H. Patel 4 . Adil A. Haji 5 . Madhav Chakolkar 6 . Anumita Bhadra
TITLE OF INVENTION	METHODOLOGY AND COMPOSITION OF MIX PROPORTION OF SELF COMPACTING PRECAST FLOOR TILE UTILISING SUGARCANE ASH
FIELD OF INVENTION	CHEMICAL
E-MAIL (As Per Record)	soni.mukesh15@gmail.com
ADDITIONAL-EMAIL (As Per Record)	soni.mukesh15@gmail.com
E-MAIL (UPDATED Online)	
PRIORITY DATE	
REQUEST FOR EXAMINATION DATE	--
PUBLICATION DATE (U/S 11A)	04/03/2022

Application Status

APPLICATION STATUS	Awaiting Request for Examination
--------------------	---

[View Documents](#)

043



Australian Government

IP Australia

CERTIFICATE OF GRANT INNOVATION PATENT

Patent number: 2021105078

The Commissioner of Patents has granted the above patent on 30 March 2022, and certifies that the below particulars have been registered in the Register of Patents.

Name and address of patentee(s):

Vishal Pande of RSM's N.N. Sattha College of Pharmacy, (DBATU) Ahmednagar Maharashtra India

Mahendra Giri of Rajashri Shahu College of Pharmacy, (SGBAU) Buldhana Maharashtra India

Rasika Bhalke of Sanjivani College of Pharmaceutical Education and Research, (SPPU) Kopergaon Maharashtra India

Vaibhav Wagh of RSM's N.N. Sattha College of Pharmacy, (DBATU) Ahmednagar Maharashtra India

Sharmila Kuskar of RSM's N.N. Sattha College of Pharmacy, (DBATU) Ahmednagar Maharashtra India

Pallavi Chede of RSM's N.N. Sattha College of Pharmacy, (DBATU) Ahmednagar Maharashtra India

Vikas Ahirrao of RSM's N.N. Sattha College of Pharmacy, (DBATU) Ahmednagar Maharashtra India

Ajinkya Pote of Rajashri Shahu College of Pharmacy, (SGBAU) Buldhana Maharashtra India

Sudhir Parbhane of RSM's N.N. Sattha College of Pharmacy, (DBATU) Ahmednagar Maharashtra India

Aishwarya Shinde of RSM's N.N. Sattha College of Pharmacy, (DBATU) Ahmednagar Maharashtra India

Title of invention:

A NOVEL FORMULATION OF CHITOSAN NANOPARTICLES

Name of inventor(s):

Pande, Vishal; Giri, Mahendra; Bhalke, Rasika; Wagh, Vaibhav; Kuskar, Sharmila; Chede, Pallavi; Ahirrao, Vikas; Pote, Ajinkya; Parbhane, Sudhir and Shinde, Aishwarya

Term of Patent:

Eight years from 7 August 2021

NOTE: This Innovation Patent cannot be enforced unless and until it has been examined by the Commissioner of Patents and a Certificate of Examination has been issued. See sections 120(1A) and 129A of the Patents Act 1990, set out on the reverse of this document.



Dated this 30th day of March 2022

Commissioner of Patents

PATENTS ACT 1990

The Australian Patents Register is the official record and should be referred to for the full details pertaining to this IP Right.

पेटेंट कार्यालय
शासकीय जर्नल

**OFFICIAL JOURNAL
OF
THE PATENT OFFICE**

निर्गमन सं. 13/2022
ISSUE NO. 13/2022

शुक्रवार
FRIDAY

दिनांक: 01/04/2022
DATE: 01/04/2022

पेटेंट कार्यालय का एक प्रकाशन
PUBLICATION OF THE PATENT OFFICE

(12) PATENT APPLICATION PUBLICATION

(21) Application No.202211017496 A

(19) INDIA

(22) Date of filing of Application :26/03/2022

(43) Publication Date : 01/04/2022

(54) Title of the invention : EXTRACTION AND ANTICANCER ACTIVITY OF MADHUCA LONGIFOLIA

(51) International classification :G06F0009455000, B32B0037120000, B01D0011020000, H01L0021683000, G16B0030000000

(86) International Application No :NA
Filing Date :NA

(87) International Publication No : NA

(61) Patent of Addition to Application Number :NA
Filing Date :NA

(62) Divisional to Application Number :NA
Filing Date :NA

(71)Name of Applicant :

1)Dr. Manmeet Singh Saluja

Address of Applicant :Principal Gurukul Pharmacy College Kota Rajasthan Email id: mansivcp@gmail.com Mob No.77708488888 -----

2)Dr. Shailesh M Kewatkar.

3)Dr. Ajay Sharma

4)Dr.Kinjal Hareshkumar Shah

5)Dr. Ashim Kumar Sen

6)Mr. Ajay Kumar

7)Ms. Shilpi Mishra

Name of Applicant : NA

Address of Applicant : NA

(72)Name of Inventor :

1)Dr. Manmeet Singh Saluja

Address of Applicant :Principal Gurukul Pharmacy College Kota Rajasthan Email id: mansivcp@gmail.com Mob No.77708488888 -----

2)Dr. Shailesh M Kewatkar.

Address of Applicant :Associate Professor & head, Department of Pharmacognosy Rajarshi Shahu College of Pharmacy, Buldana, Maharashtra. Email id: kewatar.shailesh@gmail.com Mob.no. 09589941146 -----

3)Dr. Ajay Sharma

Address of Applicant :Prof and Vice Principal, MIPS Mahakal Institute of Pharmaceutical Studie, Ujjain, MP Email id:ajaysharma85@gmail.com Mobile No. 9827687111 -----

4)Dr.Kinjal Hareshkumar Shah

Address of Applicant :M.Pharm, Ph .D. Propfessor b.PharmacyCollege, Rampura Email id: kinjaljasani9783@gmail.com Mobile No. 6352177167 -----

5)Dr. Ashim Kumar Sen

Address of Applicant :M. Pharm, Phd Professor Department of Pharmacy, Sumandeep vidyapeeth Deemed to be University, Piparia, waghodia, Vadodara 391760, Gujarat, india Email.id: ashims01@gamil.com Mobile No. 9377977540 -----

6)Mr. Ajay Kumar

Address of Applicant :M.Pharm Hod Nishat Hospiat And Institute of Pharmaceutical Sciences Barabank Uttar Pradesh Email id: majakr@gmail.com Mobile No. 7007027392 -----

7)Ms. Shilpi Mishra

Address of Applicant :M Pharm ,Assistant Professor Goel Institute of Pharmaceutical Sciences , Lucknow Uttar Pradesh Email.id:shilpimishra22@gmail.com Mobile No. 7007027392 -----

(57) Abstract :

The main object of present invention is to evaluate the anticancer activity of Madhuca longifolia Further invention related to process for preparation of extraction and isolation of medicinal plant by using different solvent.

No. of Pages : 24 No. of Claims : 3



ORIGINAL

No. 107123

भारत सरकार
GOVERNMENT OF INDIA
पेटेंट कार्यालय
THE PATENT OFFICE

CERTIFICATE OF REGISTRATION OF DESIGN

Design No. 353855-001
Date 28/11/2021 14:47:40
Reciprocity Date*
Country

Certified that the design of which a copy is annexed hereto has been registered as of the number and date given above in class 10-05 in respect of the application of such design to TESTING DEVICE FOR CHECKING PURITY AND NUTRITIONAL CONTENT OF MILK PRODUCT in the name of I.D.R. MANISH JOSHI, ASSOCIATE PROFESSOR, FACULTY OF MANAGEMENT STUDIES, SHIVAJIRAO KADAM GROUP OF INSTITUTIONS, "SANKIRTAN", R 14, ROYAL RESIDENCY, PIPLIYAHANA, RING ROAD, INDORE, MADHYA PRADESH, INDIA - 452001 2. MADHAV CHAKOLKAR, ASSISTANT PROFESSOR, DEPARTMENT OF PHARMACOGNOSY, RAJARSHI COLLEGE OF PHARMACY, BULDHANA, MAHARASHTRA, INDIA 3. RAHUL KANAOUJIYA, RESEARCH SCHOLAR, SYNTHETIC INORGANIC AND METALLO-ORGANIC RESEARCH LABORATORY, DEPARTMENT OF CHEMISTRY, UNIVERSITY OF ALLAHABAD, ALLAHABAD, UTTAR PRADESH, INDIA 4. DR. KALPANA SENGAR, DIRECTOR, BIOSENSE LIFECARE RESEARCH AND DEVELOPMENT LAB, KALPHELIX BIOTECHNOLOGIES PVT LTD, KANPUR, UTTAR PRADESH, INDIA

in pursuance of and subject to the provisions of the Designs Act, 2000 and the Designs Rules, 2001.

Controller-General of Patents, Designs and Trade Marks

*The reciprocity date (if any) which has been allowed and the name of the country.
Copyright in the design will subsist for ten years from the date of Registration, and may under the terms of the Act and Rules, be extended for a further period of five years.
This Certificate is not for use in legal proceedings or for obtaining registration abroad

ASHUTOSH SWARNKAR,
BLI CONSULTANCY PVT. LTD., 627 - A, SANJAY
COLONY, BHILWARA, RAJASTHAN - 311001

Date of Issue 07/01/2022 16:11:25



**INTELLECTUAL
PROPERTY INDIA**

PATENTS | DESIGNS | TRADE MARKS
GEOGRAPHICAL INDICATIONS



सत्यमेव जयते

भारत सरकार
GOVERNMENT OF INDIA
पेटेंट कार्यालय
THE PATENT OFFICE
पेटेंट प्रमाणपत्र
PATENT CERTIFICATE
(Rule 74 of The Patents Rules)

क्रमांक : 022118543
SL No :



पेटेंट सं. / Patent No. : 399053
आवेदन सं. / Application No. : 201821009015
फाइल करने की तारीख / Date of Filing : 12/03/2018
पेटेंटी / Patentee : 1.Dr.Mohammad Aijaz Ayyub Sheikh 2.Navale Sainath
Ramnath 3.Dr. Shirish Jain 4.Madhav Chakolkar et al. et al.

प्रमाणित किया जाता है कि पेटेंटी को, उपरोक्त आवेदन में यथाप्रकटित A PROCESS FOR PREPARATION OF PELLETS OF THEOPHYLLINE DRUG नामक आविष्कार के लिए, पेटेंट अधिनियम, 1970 के उपबंधों के अनुसार आज तारीख मार्च 2018 के बारहवें दिन से बीस वर्ष की अवधि के लिए पेटेंट अनुदत्त किया गया है।

It is hereby certified that a patent has been granted to the patentee for an invention entitled A PROCESS FOR PREPARATION OF PELLETS OF THEOPHYLLINE DRUG as disclosed in the above mentioned application for the term of 20 years from the 12th day of March 2018 in accordance with the provisions of the Patents Act,1970.



अनुदान की तारीख : 13/06/2022
Date of Grant :

पेटेंट नियंत्रक
Controller of Patent

टिप्पणी - इस पेटेंट के नवीकरण के लिए फीस, यदि इसे बनाए रखा जाना है, मार्च 2020 के बारहवें दिन को और उसके पश्चात प्रत्येक वर्ष में उसी दिन देय होगी।

Note. - The fees for renewal of this patent, if it is to be maintained will fall / has fallen due on 12th day of March 2020 and on the same day in every year thereafter.



Office of the Controller General of Patents, Designs & Trade Marks
Department of Industrial Policy & Promotion,
Ministry of Commerce & Industry,
Government of India

(<http://ipindia.nic.in/index.htm>)



(<http://ipindia.nic.in/index.htm>)

Application Details

APPLICATION NUMBER	202221041441
APPLICATION TYPE	ORDINARY APPLICATION
DATE OF FILING	20/07/2022
APPLICANT NAME	1 . Madhav Devendra chakolkar 2 . Dr. Shirish Premachand Jain 3 . Vaibhav Uddhav Chinchole 4 . Shubham Subhash Sarode
TITLE OF INVENTION	"A DIAGNOSTIC TEST BY USING SAPONINS FOR DETECTION OF OCCULT BLOOD IN URINE AND STOOL SAMPLE"
FIELD OF INVENTION	BIO-CHEMISTRY
E-MAIL (As Per Record)	tmindia123@gmail.com
ADDITIONAL-EMAIL (As Per Record)	tmindia123@gmail.com
E-MAIL (UPDATED Online)	
PRIORITY DATE	
REQUEST FOR EXAMINATION DATE	--
PUBLICATION DATE (U/S 11A)	05/08/2022

Application Status

APPLICATION STATUS	Awaiting Request for Examination
--------------------	---

[View Documents](#)

049



Office of the Controller General of Patents, Designs & Trade Marks
Department of Industrial Policy & Promotion,
Ministry of Commerce & Industry,
Government of India

(<http://ipindia.nic.in/index.htm>)



(<http://ipindia.nic.in/index.htm>)

Application Details

APPLICATION NUMBER	202121042106
APPLICATION TYPE	ORDINARY APPLICATION
DATE OF FILING	17/09/2021
APPLICANT NAME	1 . Madhav Devendra Chakolkar 2 . Akshay Sanjay Mahalle 3 . Indira Puroshattam Dahibhat 4 . Shirish Premachand Jain 5 . Dr. Puroshottam Gangane 6 . Sachin Rajendra Jadhav 7 . Dr. Swati S. Tathod
TITLE OF INVENTION	FORMULATION FOR THE TREATMENT OF PARONYCHIA AND METHOD OF PREPARATION THEREOF
FIELD OF INVENTION	BIOTECHNOLOGY
E-MAIL (As Per Record)	infobli100@gmail.com
ADDITIONAL-EMAIL (As Per Record)	sjgawande@gmail.com
E-MAIL (UPDATED Online)	
PRIORITY DATE	
REQUEST FOR EXAMINATION DATE	--
PUBLICATION DATE (U/S 11A)	12/08/2022

Application Status

APPLICATION STATUS	Awaiting Request for Examination
--------------------	---

050

Design Application Details

Application Number:

364452-001

Cbr Number:

201763

Cbr Date:

20/05/2022 09:37:33

Applicant Name:

1. Madhav Chakolkar 2. Satish Panjabrao Shelke 3. Purushottam Gangane
4. Dr. Sohan Chitlange

Design Application Status

Application Status:

Design Accepted and Published, Journal No is 41/2022 and Journal Date is 14/10/2022

[Back \(/DesignApplicationStatus/\)](#)

Disclaimer: Application status is available for the application filed on or after 1st April 2009 with application no 222230. The information under " Design Application Status" is dynamically retrieved and is under testing, therefore the information retrieved by this system is not valid for any legal proceedings under the Design Act 2000. In case of any discrepancy you may contact the appropriate Patent Office or send your comments to following email IDs:

Design Office, Kolkata : controllerdesign.ipo@nic.in

Controller General of Patents, Designs and Trademarks

Design Application Details

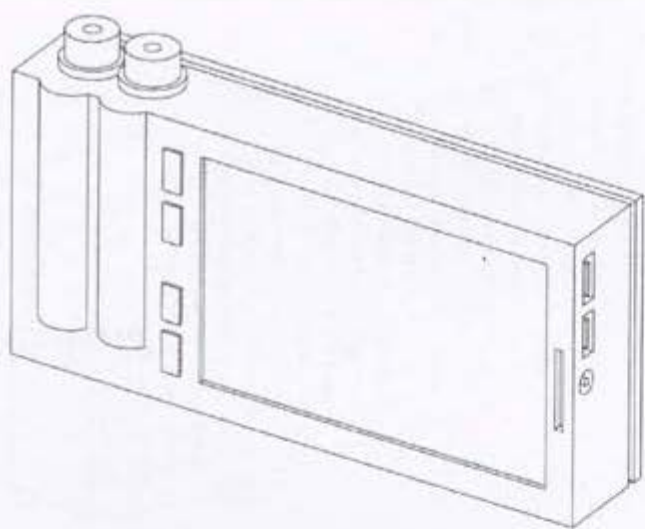

Design Number: 364452-001

Filing Date: 20/05/2022 09:37:33

Article Name: Device for blood sample analysis

Class: 24-01-APPARTUS EQUIPMENT FOR DOCTORS, HOSPITALS AND LABORATORIES

Journal Number: 41/2022

Journal Date: 14/10/2022 00:00:00

Applicant Detail

Sl. No.	APPLICANT NAME	APPLICANT ADDRESS
1	Madhav Chakolkar	Shanti Nagar, bypass karanja (lad), Washim, Maharashtra
2	Satish Panjabrao Shelke	Rajarshi Shahu College of Pharmacy, Buldana, Maharashtra
3	Purushottam Gangane	Dadasaheb Balpande College of Pharmacy, Nagpur, Maharashtra
4	Dr. Sohan Chitlange	D. Y. Patil College of Pharmacy, Pimpri, Pune, Maharashtra

Priority Details

Record Not Found !

Design Application Details

Application Number:

356181-001

Cbr Number:

211678

Cbr Date:

05/01/2022 13:25:19

Applicant Name:

1. Neelam Sanjeev Kumar
2. Mohd Yunus Khan
3. Dr. Nandkishor Dinkarrao Gawhale
4. Madhav Chakolkar

Design Application Status

Application Status:

Design Accepted and Published, Journal No is 11/2022 and Journal Date is 18/03/2022

[Back \(/DesignApplicationStatus/\)](#)

Disclaimer: Application status is available for the application filed on or after 1st April 2009 with application no 222230. The information under " Design Application Status" is dynamically retrieved and is under testing, therefore the information retrieved by this system is not valid for any legal proceedings under the Design Act 2000. In case of any discrepancy you may contact the appropriate Patent Office or send your comments to following email IDs:

Design Office, Kolkata : controllerdesign.ipo@nic.in

Controller General of Patents, Designs and Trademarks

Design Application Details

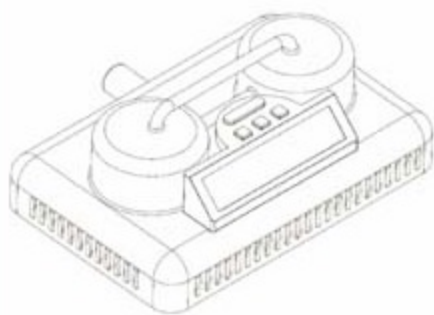

Design Number: 356181-001

Filing Date: 05/01/2022 13:25:19

Article Name: Oxygen Generator

Class: 24-02-MEDICAL INSTRUMENTS, INSTRUMENTS AND TOOLS FOR LABORATORY USE

Journal Number: 11/2022

Journal Date: 18/03/2022 00:00:00

Applicant Detail

SI. No.	APPLICANT NAME	APPLICANT ADDRESS
1	Neelam Sanjeev Kumar	Assistant Professor (SG), Department of BME Saveetha School of Engineering, Saveetha Institute of Medical and Technical Sciences Thandalam, Chennai - 602105
2	Mohd Yunus Khan	Research Scholar,, Department of Mechanical Engineering, National Institute of Technical Teachers Training and Research (NITTTR), Chandigarh
3	Dr. Nandkishor Dinkarrao Gawhale	Asha Colony Tapovan road Amravati 444602
4	Madhav Chakolkar	Assistant Prfoessor, Department of Pharmacognosy, Rajarshi College of Pharmacy, Buldhana, India

Priority Details

Record Not Found !

Urkunde

über die Eintragung des
Gebrauchsmusters Nr. 20 2022 104 209

Bezeichnung:

Moderne Wirkstoffformulierung für die Krebstherapie

IPC:

A61K 36/82

Inhaber/Inhaberin:

Bhise, Manish Ramesh, Prof., Akola, Maharashtra, IN
Chandurkar, Pranjali Wamanrao, Prof., Shirpur, Maharashtra, IN
Goda, Chirag Chandrakant, Dr., Jeddah, SA
Kandalkar, Ashish Madhukar, Dr., Akola, Maharashtra, IN
Pahuja, Sunny Ramchand, Prof., Akola, Maharashtra, IN
Patil, Vikas Prakash, Prof., Shirpur, Maharashtra, IN
Patond, Vishal Babulal, Prof., Akola, Maharashtra, IN
Shejol, Vinayak Mahadeo, Prof., Malkapur, Maharashtra, IN
Shelke, Satish Panjabrao, Prof., Buldhana, Maharashtra, IN
Shukla, Karunakar, Dr., Ujjain, Madhya Pradesh, IN
Vasu, Sanjay Namdevrao, Prof., Akola, Maharashtra, IN

Tag der Anmeldung:

25.07.2022

Tag der Eintragung:

26.09.2022

Die Präsidentin des Deutschen Patent- und Markenamts



Cornelia Rudloff-Schäffer

München, 26.09.2022





(12) **Gebrauchsmusterschrift**

(21) Aktenzeichen: **20 2022 105 415.0**

(22) Anmeldetag: **27.09.2022**

(47) Eintragungstag: **05.10.2022**

(45) Bekanntmachungstag im Patentblatt: **10.11.2022**

(51) Int Cl.: **A61J 7/04 (2006.01)**

F25B 21/02 (2006.01)

B65D 83/04 (2006.01)

(73) Name und Wohnsitz des Inhabers:

Chakolkar, Madhav Devendra, Washim, Maharashtra, IN; Gangane, Purushottam Shridharrao, Nagpur, Maharashtra, IN; Gawhale, Nandkishor, Amravati, Maharashtra, IN; Joshi, Amit, Ujjain, Madhya Pradesh, IN; Kewatkar, Shailesh, Buldana, Maharashtra, IN; Kulkarni, Abhijeet Dattatraya, Ahmednagar, Maharashtra, IN; Saluja, Manmeet Singh, Kota, Rajasthan, IN; Sawarkar, Harigopal Shalimar, Amravati, Maharashtra, IN; Shaikh, Mohammad Aijaz Ayyub, Washim, Maharashtra, IN

(74) Name und Wohnsitz des Vertreters:

Hohendorf Kierdorf Patentanwälte PartGmbH, 50672 Köln, DE

Die folgenden Angaben sind den vom Anmelder eingereichten Unterlagen entnommen.

(54) Bezeichnung: **Eine Aufbewahrungsbox für digitale Medikamente**

(57) Hauptanspruch: Aufbewahrungsbox für digitale Medikamente, dadurch gekennzeichnet;

eine Box ist mit einem thermoelektrischen Peltier-Kühlsystem ausgestattet, das eine Konstruktion mit geschlossener Tür aufweist, die es ermöglicht, die Temperatur aufrechtzuerhalten, die zum Aufbewahren der Medikamente erforderlich ist,

einen Berührungsbildschirm [105] eingebettet mit adaptiver Konfiguration, konfiguriert an einer geschlossenen Tür, um die Verschreibung anzuzeigen, die von einem eingebauten Scanner gescannt wird, der an der Tür in Form einer Kamera [104] angebracht ist, platziert oben auf dem Bildschirm [105];

und eingebautem 2 GB RAM und 16 GB Speicher zum Speichern von medizinischen Daten und der Krankengeschichte des Patienten;

ein eingebautes mobiles Motherboard und ein USB-Anschluss [106] sind dafür ausgelegt, das Rezept von Flash-Laufwerken hochzuladen.

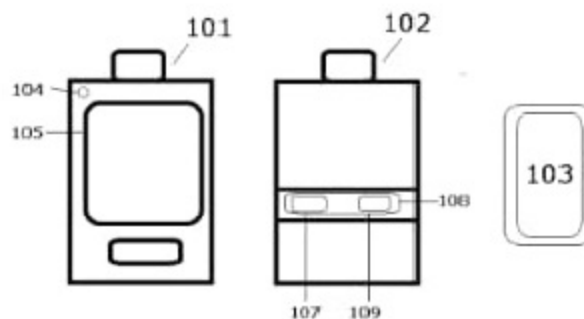



Office of the Controller General of Patents, Designs & Trade Marks
Department of Industrial Policy & Promotion,
Ministry of Commerce & Industry,
Government of India

(<http://ipindia.nic.in/index.htm>)



(<http://ipindia.nic.in/index.htm>)

Application Details

APPLICATION NUMBER	202121054080
APPLICATION TYPE	ORDINARY APPLICATION
DATE OF FILING	23/11/2021
APPLICANT NAME	1 . Dr. Gopal Ramchandra Kulkarni 2 . Dr. Akhilesh Kumar 3 . Fardin Ahmed Niloy 4 . Fazeel Abid 5 . Rohit Salkute 6 . N. Priya
TITLE OF INVENTION	A NOVEL METHOD FOR PREVENTION OF SECURITY ATTACK ON CLOUD MEDICAL DATA USING ARTIFICIAL INTELLIGENCE AND IOT
FIELD OF INVENTION	BIO-MEDICAL ENGINEERING
E-MAIL (As Per Record)	soni.mukesh15@gmail.com
ADDITIONAL-EMAIL (As Per Record)	soni.mukesh15@gmail.com
E-MAIL (UPDATED Online)	
PRIORITY DATE	
REQUEST FOR EXAMINATION DATE	--
PUBLICATION DATE (U/S 11A)	03/12/2021

Application Status

APPLICATION STATUS	Awaiting Request for Examination
--------------------	---

[View Documents](#)

057



Office of the Controller General of Patents, Designs & Trade Marks
Department of Industrial Policy & Promotion,
Ministry of Commerce & Industry,
Government of India

(<http://ipindia.nic.in/index.htm>)



(<http://ipindia.nic.in/index.htm>)

Application Details	
APPLICATION NUMBER	202111057428
APPLICATION TYPE	ORDINARY APPLICATION
DATE OF FILING	09/12/2021
APPLICANT NAME	1 . Dr. Sheela Devi 2 . Dr. Smita Sharma 3 . Dr. Sheshang Degadwala 4 . Dipak Bhusari 5 . Balaji Ramkumar Rajagopal 6 . Nabamita Deb
TITLE OF INVENTION	DEEP LEARNING ENABLED CLOUD BASED IOT AND MACHINE LEARNING IMPLEMENTED SYSTEM FOR DETECTING AND PREVENTING HEART ABNORMALITIES
FIELD OF INVENTION	COMPUTER SCIENCE
E-MAIL (As Per Record)	soni.mukesh15@gmail.com
ADDITIONAL-EMAIL (As Per Record)	soni.mukesh15@gmail.com
E-MAIL (UPDATED Online)	
PRIORITY DATE	
REQUEST FOR EXAMINATION DATE	--
PUBLICATION DATE (U/S 11A)	17/12/2021

Application Status	
APPLICATION STATUS	Awaiting Request for Examination

058



Office of the Controller General of Patents, Designs & Trade Marks
Department of Industrial Policy & Promotion,
Ministry of Commerce & Industry,
Government of India

(<http://ipindia.nic.in/index.htm>)



(<http://ipindia.nic.in/index.htm>)

Application Details

APPLICATION NUMBER	202111058061
APPLICATION TYPE	ORDINARY APPLICATION
DATE OF FILING	13/12/2021
APPLICANT NAME	1 . Rahul Kanaoujiya 2 . Madhav Chakolkar 3 . Dr. Hemant Gangrude 4 . Dr. Manisha M. Kodape 5 . Ajaykumar Ramhari Motghare 6 . Dr. Shubhajit Halder
TITLE OF INVENTION	Synthesis of N-Mannich Bases of 3,4 Dihydropyrimidin-2(1H)-ones by using Fe ₃ O ₄ @SiO ₂ @Et-PhSO ₃ H as magnetically retrievable nanocatalysts
FIELD OF INVENTION	CHEMICAL
E-MAIL (As Per Record)	soni.mukesh15@gmail.com
ADDITIONAL-EMAIL (As Per Record)	soni.mukesh15@gmail.com
E-MAIL (UPDATED Online)	
PRIORITY DATE	
REQUEST FOR EXAMINATION DATE	--
PUBLICATION DATE (U/S 11A)	24/12/2021

Application Status

APPLICATION STATUS	Awaiting Request for Examination
--------------------	---



Office of the Controller General of Patents, Designs & Trade Marks
Department of Industrial Policy & Promotion,
Ministry of Commerce & Industry,
Government of India

(<http://ipindia.nic.in/index.htm>)



(<http://ipindia.nic.in/index.htm>)

Application Details

APPLICATION NUMBER	202121049931
APPLICATION TYPE	ORDINARY APPLICATION
DATE OF FILING	31/10/2021
APPLICANT NAME	1 . Dr. Shailesh M Kewatkar 2 . Dr. Shirish P Jain 3 . Mr. Dipak V Bhusari 4 . Mr. Madhav Chakolkar
TITLE OF INVENTION	HERBAL HAIR OIL FOR HAIR FALL TREATMENT
FIELD OF INVENTION	CHEMICAL
E-MAIL (As Per Record)	tmindia123@gmail.com
ADDITIONAL-EMAIL (As Per Record)	kewatar.shailesh@gmail.com
E-MAIL (UPDATED Online)	
PRIORITY DATE	
REQUEST FOR EXAMINATION DATE	--
PUBLICATION DATE (U/S 11A)	31/12/2021

Application Status

APPLICATION STATUS	Awaiting Request for Examination
--------------------	---

[View Documents](#)



Office of the Controller General of Patents, Designs & Trade Marks
Department of Industrial Policy & Promotion,
Ministry of Commerce & Industry,
Government of India

(<http://ipindia.nic.in/index.htm>)



(<http://ipindia.nic.in/index.htm>)

Application Details

APPLICATION NUMBER	201921024417
APPLICATION TYPE	ORDINARY APPLICATION
DATE OF FILING	19/06/2019
APPLICANT NAME	1 . Mr. Madhav Chakolkar 2 . Dr. Shirish Premchand Jain 3 . Dr. Shailesh Madhukar Kewatkar 4 . Mr. Anand Bhanudas Kafre 5 . Ankush Arun Sapkal 6 . Vrushali Eknath kalwaghe
TITLE OF INVENTION	APPARATUS FOR THE EXTRACTION OF A LIPID FROM A SOLID MATERIAL
FIELD OF INVENTION	BIO-MEDICAL ENGINEERING
E-MAIL (As Per Record)	sjgawande@gmail.com
ADDITIONAL-EMAIL (As Per Record)	infobli100@gmail.com
E-MAIL (UPDATED Online)	ashutosh@bliconsultancy.co.in
PRIORITY DATE	
REQUEST FOR EXAMINATION DATE	--
PUBLICATION DATE (U/S 11A)	16/10/2020

Application Status

APPLICATION STATUS	Awaiting Request for Examination
--------------------	---

[View Documents](#)

061



Office of the Controller General of Patents, Designs & Trade Marks
Department of Industrial Policy & Promotion,
Ministry of Commerce & Industry,
Government of India

(<http://ipindia.nic.in/index.htm>)



(<http://ipindia.nic.in/index.htm>)

Application Details	
APPLICATION NUMBER	201921039880
APPLICATION TYPE	ORDINARY APPLICATION
DATE OF FILING	02/10/2019
APPLICANT NAME	1 . Dr. Shirish P. Jain 2 . Mr. Amit Kumar K. Tawri 3 . Mr. Ankush P. Kharche 4 . Dr. Shailesh M. Kewatkar 5 . Mr. Gyaneshwar G Farkale 6 . Mr. Madhav D. Chakolkar
TITLE OF INVENTION	"NOVEL SOXHLET APPARATUS"
FIELD OF INVENTION	METALLURGY
E-MAIL (As Per Record)	tmindia123@gmail.com
ADDITIONAL-EMAIL (As Per Record)	kewatkar.shailesh@gmail.com
E-MAIL (UPDATED Online)	
PRIORITY DATE	
REQUEST FOR EXAMINATION DATE	--
PUBLICATION DATE (U/S 11A)	23/10/2020

Application Status	
APPLICATION STATUS	Awaiting Request for Examination

			View Documents
--	--	--	--------------------------------

062



Office of the Controller General of Patents, Designs & Trade Marks
Department of Industrial Policy & Promotion,
Ministry of Commerce & Industry,
Government of India

(<http://ipindia.nic.in/index.htm>)



(<http://ipindia.nic.in/index.htm>)

Application Details

APPLICATION NUMBER	201921039358
APPLICATION TYPE	ORDINARY APPLICATION
DATE OF FILING	28/09/2019
APPLICANT NAME	1 . Prakash Namdeo Kendre 2 . Somnath Kedarling Vibhute 3 . Shirish Premchand Jain
TITLE OF INVENTION	COMPOSITION AND PROCESS FOR PREPARATION OF CURCUMIN FILM FORMING SPRAY FOR WOUND HEALING
FIELD OF INVENTION	CHEMICAL
E-MAIL (As Per Record)	sjgawande@gmail.com
ADDITIONAL-EMAIL (As Per Record)	infobli100@gmail.com
E-MAIL (UPDATED Online)	ashutosh@bliconsultancy.co.in
PRIORITY DATE	
REQUEST FOR EXAMINATION DATE	--
PUBLICATION DATE (U/S 11A)	30/10/2020

Application Status

APPLICATION STATUS	Awaiting Request for Examination
--------------------	---

[View Documents](#)